

in: B. Pridaux and K. Rzazewski (eds)
Super-Intense Laser Atom Physics pp 15-23 (SILAP 2000),
Kluwer Academic 2001

DOUBLE IONIZATION IN STRONG FIELDS:
ION MOMENTA AND CORRELATED ELECTRON MOMENTA

A. Staudte², T. Weber², H. Giessen³, G. Urbasch³, M. Vollmer³
M. Weckenbrock², O. Jagutzki², L. Spielberger² R. Dörner^{1*}

January 3, 2002

What happens when an atom is subjected to very intense light of a wavelength long compared to the ionization potential? We review recent experiments [1, 2, 3] in which this question is addressed experimentally by measuring the momenta of doubly charged Helium and Argon and the momentum correlation between the two emitted electrons from double ionization in the focus of a Ti:Sapphire laser at intensities of several $10^{14}W/cm^2$.

Already soon after short pulses with sufficient power became available it was discovered that double ionization occurs orders of magnitude more likely than what one would expect from a process in which each of the electrons couples to the field independently (see e.g. [4, 5] and [6] for a recent review). It became clear that electron-electron correlation was important to enable this process [7, 8, 9, 10, 11, 12, 13, 14]. The situation is comparable to ionization by synchrotron radiation. Here only one photon is absorbed and without electron-electron correlation the probability of ejecting the second electron would be zero. For synchrotron radiation a ratio of double to single ionization of up to about 3% (depending on the photon energy) is found. With synchrotron radiation today many very detailed experimental and theoretical studies of energy and angular distribution of both emitted electrons and the recoiling doubly charged ion are available (see eg. [15] for the pioneering experiment, [16, 17, 18] for studies using the technique used in the present study and [19] for a recent review). For the case of double ionization by femto second laser impact however, the experiments are still in their infancy. Until 1999 only total ion yield measurements were available. The reason is, that coincidence experiments in strong laser fields are extremely difficult. To assure that two fragments (two electrons or an electron and an ion) which are detected in coincidence originate from the same atom, the total single ionization rate in the focus (not only the number of particles detected in the detector) has to be far below unity. Given that the ratio of double to single ionization is only 10^{-4} for Helium and a few % for Argon extremely low counts rates are achievable with 1kHz repetition rates lasers. To facilitate such studies it is imperative to use spectrometers which have 4π solid angle for all particles to be detected.

In the present study we have used COLTRIMS (Cold Target Recoil Ion Momentum Spectroscopy) for momentum space imaging of ions and electrons. This technique has been developed originally for the study of ion impact ionization and has than be successfully used for experiment with synchrotron radiation, antiproton impact and electron impact (see [20] for a recent review). The laser is focussed onto a very dilute supersonic beam (background pressure 10^{-10} mbar, local jet gas pressure between 10^{-8} and 10^{-5} mBar. The gas pressure is adjusted such that only 0.1-0.3 ions are created per laser pulse. The ion and the electrons are guided by weak electric fields towards two position sensitive channel plate detectors. From the time of flight and the position of impact of each particle the charge state and the three dimensional momentum vector is obtained.

For single ionization the momentum of the recoiling ion is equal and opposite to the ejected electron momentum, if the pulse is short enough, that the electron does not leave the focus. For the coincident detection of electron and ion this

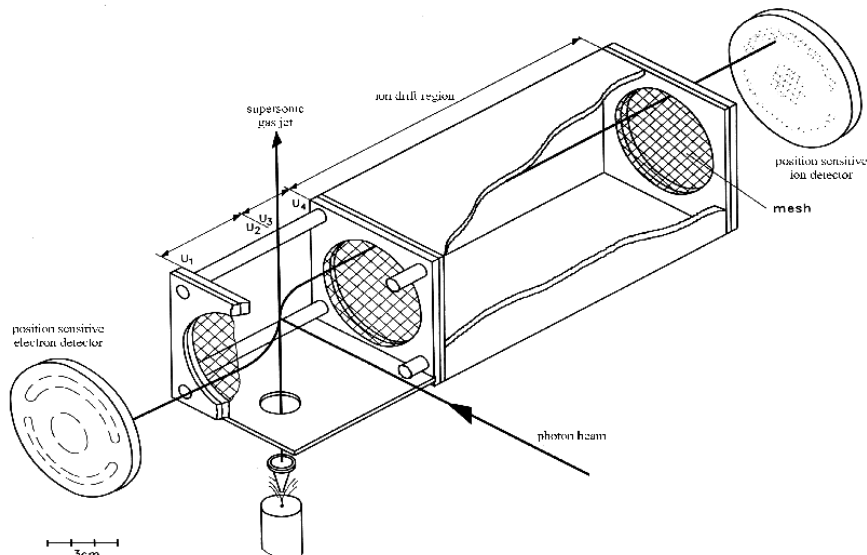

Figure 1: Typical COLTRIMS setup. The gas nozzle is cooled to 15-30 K, The laser is focussed into the supersonic gas jet. The electron detector is located on the left side of the spectrometer and the ion detector on the right side. (from [21]). For each particle the position of impact on the detector and the time of flight with respect to the laser pulse is measured.

allows an online monitoring of the events where more than one ion per pulse was produced and the ion and electron detected result from different atoms. Such events are located outside the diagonal of momentum conservation of figure 2. The width of the diagonal also shows the overall resolution of the system. It is about 0.1 a.u. for helium and about 0.4 a.u. for argon, since the gas jet yields much more efficient cooling for helium than for argon.

The ion momentum distribution for doubly charged He ions is shown in figure 3 for different intensities. At the highest intensity a double peak structure is found.

How does the ion receive its momentum? In the direction transverse to the electric field, the ionic momentum is solely a result of electron-ion interaction during the ionization process. This could be for example a scattering of the electrons at the core or a reminiscence of the initial state momentum distribution. Figures 3 d-f show that this transverse momentum distribution becomes wider with increasing peak power. In the rescattering model [22, 9], this transverse momentum would be mainly a result of the momentum transfer in the (e,2e) collision. However, the distributions shown in figure 3d-f are about a factor

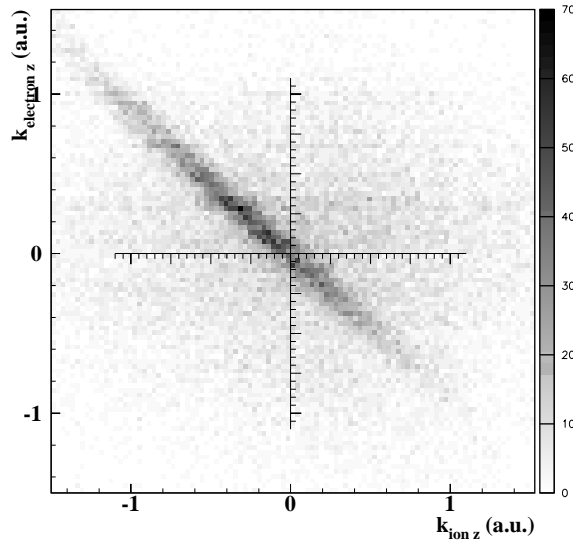

Figure 2: Momentum correlation between He^{1+} ion and electrons created in the focus of a 220 fsec, 800nm laser pulse at peak intensities of $4 \cdot 10^{14} \text{ W/cm}^2$. The horizontal axis shows the momentum component of the He^{1+} ion along the polarization of the laser field, the vertical axis the momentum of the detected electron.

2-4 narrower than the transverse recoil-ion momentum distribution for double ionization of helium by 270-2000 eV electron impact measured by Jagutzki et al [23].

The component of the momenta parallel to the polarization is mainly a result of the acceleration of the ion in the field. For an estimate, we assume that the first electron is removed at time t_1 and the ion switches its charge from 1^+ to 2^+ at time t_{12} . If both electrons are removed without momentum transfer to the ion, the ion momentum at the time t_∞ at the end of the laser pulse with envelope of the electric field strength $E(t)$ is given by (in atomic units)

$$p_z^{He^{2+}}(t_\infty) = \int_{t_1}^{t_{12}} E(t) \sin \omega t dt + 2 \int_{t_{12}}^{t_\infty} E(t) \sin \omega t dt. \quad (1)$$

For the TS1/shake process, which is dominant for double ionization by synchrotron radiation, one might assume $\omega(t_1 - t_{12}) \ll \pi$, i.e. if the double ionization takes place in a time interval short compared to the optical cycle. Then equation 1 describes the motion of a particle with charge 2^+ in the oscillating field. The final momentum depends on the phase ωt_1 at the instant of

creation of the ion. The maximum value of $2\sqrt{4U_p}$ (shown by the full arrows in figure 3(a-c)) corresponds to the creation of the ion when the optical field strength is zero. The data show clearly that the He^{2+} ion yield is strongly suppressed in the region approaching $2\sqrt{4U_p}$. The width of the peak in figure 3c corresponds to $\pm 1/4$ field period centered around the maximum field strength. This is consistent with prediction of a time dependent calculation of the He^{2+} yield of Parker and coworkers [24].

Contrary to the shake-off/TS1 process, in the rescattering model there is a significant time delay between the liberation of the first electron and its re-encounter with the ion which leads to double ionization. An estimate of the integral for the rescattering process is shown by the dashed arrow. This neglects a possible momentum transfer in the recollision process. The hatched area show an estimate including this momentum transfer. These findings are in agreement with results of a similar experiment performed by Moshhammer and coworkers for Ne double and triple ionization [25]. Recently Becker and Faisal succeeded in the first calculations of recoil ion momentum distributions and could reproduce the observed double peak structure [26]. They could show that it is a result of the final state interaction of the laser field with the electrons (and the ion).

For argon atoms we succeeded in measuring the ion momentum distribution also at intensities where double ionization proceeds sequentially [2]. In figure 4 the evolution of the argon ion spectrum with increasing laser intensity is shown. With the onset of sequential ionization the momentum distribution becomes narrower and peaks at zero momentum. It resembles a distribution of singly charged ions convoluted with itself.

Figure 5 shows the momentum correlation between the two electrons emitted from an argon atom at an intensity where nonsequential ionization dominates. We find a distinct maximum for both electrons traveling to the same side with similar momentum. While electron repulsion tries to drive the electrons to opposite sides (as observed with synchrotron radiation) here obviously the action of the laser field on the electrons determines their final momenta. It is the laser field which drives both electrons to the same side. Again this indicates that both electrons are set free simultaneously with a phase shift of about 35 deg with respect to the maximum of the field. This is in agreement with the expectation within the rescattering model if one takes excitation as an intermediate step into account. Recently Sacha and Eckhardt [27, 28] proposed a classical model for double ionization, which divides the process into two stages. First, a rescattering process creates a highly excited complex of two electrons. Then, the external laser field allows this compound state to decay in such a way that the electrons escape preferredly to the same side and therefore is in good agreement with our observations.

In the second and fourth quadrant in figure 5 a weak accumulation of electron momenta is distinguishable. Events in these quadrants are corresponding to double ionization with both electrons escaping to opposite sides. The nature of these events will have to be examined in the future.

At the moment the technique of COLTRIMS is being widely applied in ultrashort, intense laser physics not only to atoms but to molecules as well. We

expect more light will be shed on light-matter interaction in the near future.

Acknowledgements We are indebted to Horst Schmidt-Böcking for enthusiastic support of this project and R. Moshhammer and J. Ullrich for many helpful discussions. Our analysis of the influence of the laser field on the final state momenta emerged from many fruitful discussion with A. Becker, F.H.M. Faisal. This work is supported by DFG, BMBF, GSI and DAAD. R.D. acknowledges supported by the Heisenberg-Programm of the DFG. The Marburg group thanks the Land Hessen and the DFG for support through their SFB383 and their Graduiertenkolleg 'Optoelektronik mesoskopischer Halbleiter'. We are grateful to W.W. Rühle for continuous support. We thank Roentdek GmbH for providing the position sensitive detectors.

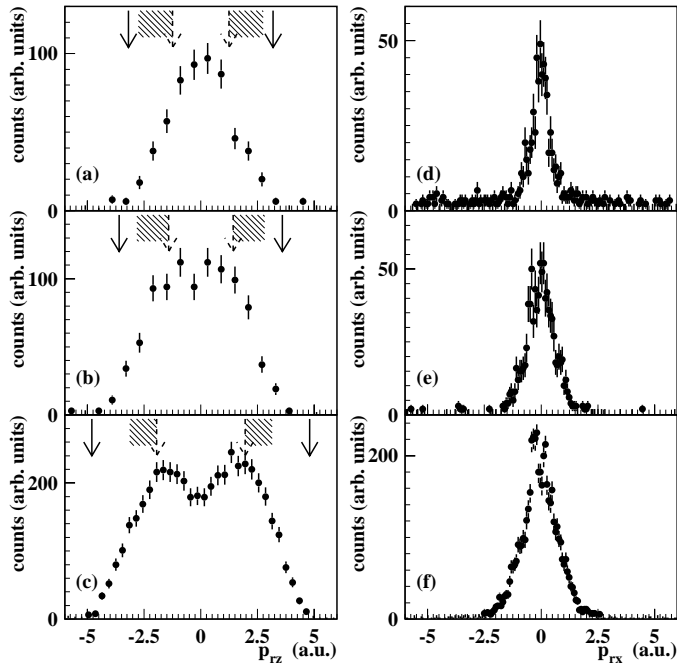

Figure 3: (a-c) distribution of He^{2+} ion momenta in the direction of the polarization integrated of the two momentum components perpendicular to the polarization, (d-f) momentum distribution in the direction of the photon propagation. The full arrows indicate a momentum of $2\sqrt{4U_p}$ which is the upper bound if the two electrons are liberated in a time interval short compared to the optical cycle, the dashed arrows indicate the momenta in a rescattering model without momentum transfer in the (e,2e) collision the hatched area is an estimate in the rescattering model with momentum transfer (see text). The peak intensities are $2.9 \cdot 10^{14}$ W/cm² (a and d), $3.8 \cdot 10^{14}$ W/cm² (b and e) and $6.6 \cdot 10^{14}$ W/cm² (c and f) (from [1]).

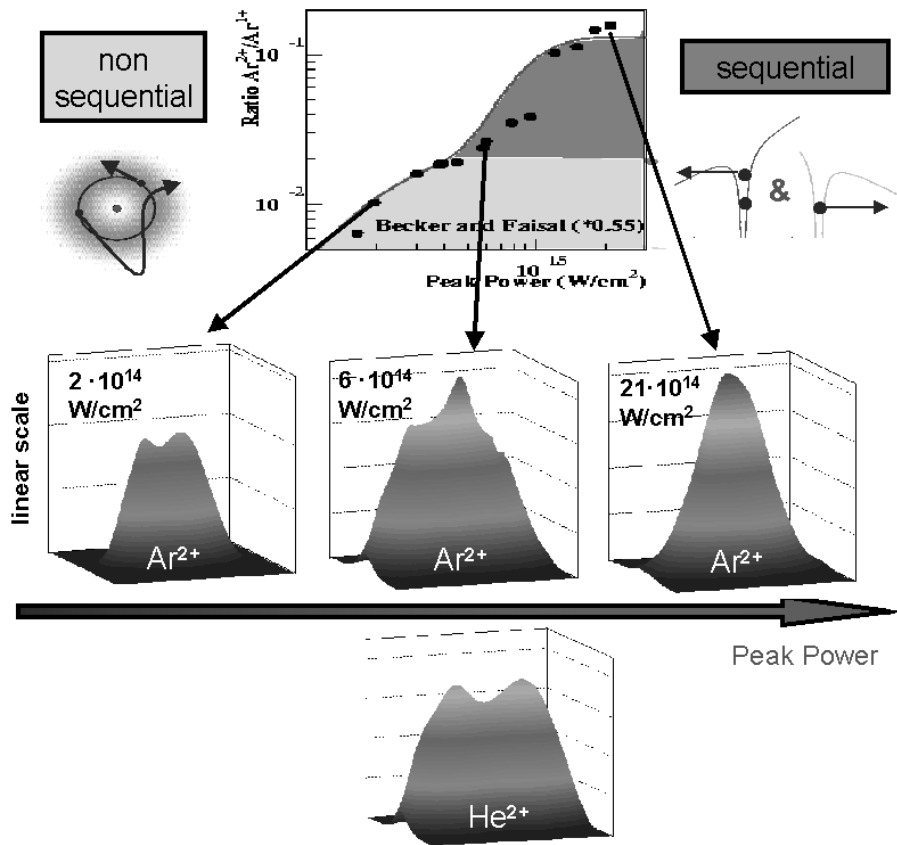

Figure 4: Evolution of the ion momentum distribution with increasing light intensity. Light intensities are pointed out in a distribution that shows the $\text{Ar}^{2+}/\text{Ar}^+$ yield vs. intensity. A drastic change in the argon ion momentum distribution can be observed when entering the sequential ionization regime. Meanwhile at $6 \cdot 10^{14} \text{ W/cm}^2$ the helium distribution still shows the double peak. Measurements at intensities high enough to turn on sequential double ionization in helium are difficult due to the strong increase in signal from the residual gas.

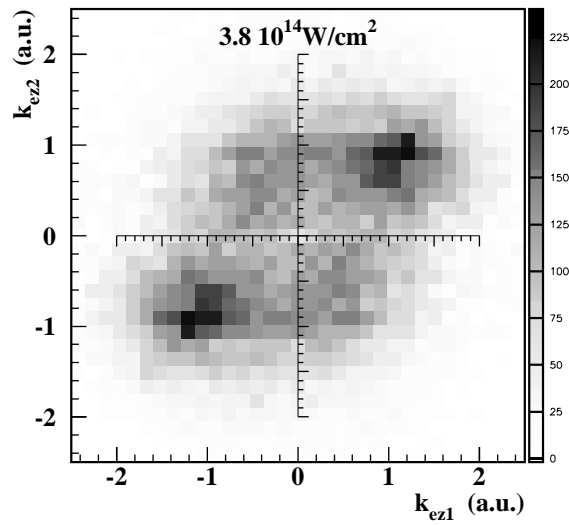

Figure 5: Momentum correlation between the two emitted electrons when a Ar^{2+} ion is produced in the focus of a 220 fsec, 800nm laser pulse at peak intensities of $3.8 \cdot 10^{14} \text{ W/cm}^2$. The horizontal axis shows the momentum components of one electron along the polarization of the laser field, the vertical axis the same momentum component of the corresponding second electron. Same sign of the momenta for both electrons means emission to the same half sphere. The data are integrated over the momentum components in the direction perpendicular to the polarization. The grey shading shows the differential rate in arbitrary units (adapted from [3]).

Bibliography

- [1] Th. Weber, M. Weckenbrock, A. Staudte, L. Spielberger, O. Jagutzki, V. Mergel, G. Urbasch, M. Vollmer, H. Giessen, , and R. Dörner. *Phys. Rev. Lett.*, 84:443, 2000.
- [2] Th. Weber, M. Weckenbrock, A. Staudte, L. Spielberger, O. Jagutzki, V. Mergel, G. Urbasch, M. Vollmer, H. Giessen, , and R. Dörner. *J. Phys.*, B33(L127), 2000.
- [3] Th. Weber, H. Giessen, M. Weckenbrock, A. Staudte, L. Spielberger, O. Jagutzki, V. Mergel, G. Urbasch, M. Vollmer, , and R. Dörner. *Nature*, 404:608, 2000.
- [4] D.N. Fittinghoff, P.R. Bolton, B. Chang, and K.D. Kulander. *Phys. Rev. Lett.*, 69:2642, 1992.
- [5] B. Walker, B. Sheehy, L.F. DiMauro, P. Agostini, K.H. Schafer, and K.C. Kulander. *Phys. Rev. Lett.*, 73:1227, 1994.
- [6] P. Lambropoulos, P. Maragakis, and J. Zhang. *Physics Reports*, 305:203, 1998.
- [7] A. Becker and F.H.M. Faisal. *J. Phys.*, B29:L197, 1996.
- [8] A. Becker and F.H.M. Faisal. *J. Phys.*, B32:L335, 1999.
- [9] P.B. Corkum. *Phys. Rev. Lett.*, 71:1994, 1993.
- [10] K.C. Kulander, J. Cooper, and K.J. Schafer. *Phys. Rev.*, A51:561, 1995.
- [11] W.C. Liu, J.H. Eberly, S.L. Haan, and R. Grobe. *Phys. Rev. Lett.*, 83:520, 1999.
- [12] J.B. Watson, A. Sanpera, D.G. Lappas, P.L. Knight, and K. Burnett. *Phys. Rev. Lett.*, 78:1884, 1997.
- [13] D.G. Lappas and R. van Leeuwen. *J. Phys.*, B31:L249, 1998.
- [14] K.J. LaGattuta and J.S. Cohen. *J. Phys.*, B31:5281, 1998.

- [15] O. Schwarzkopf, B. Krässig, V. Schmidt, F. Maulbetsch, and J. Briggs. *J. Phys.*, **B27**:L347–50, 1994.
- [16] R. Dörner, J. Feagin, C.L. Cocke, H. Bräuning, O. Jagutzki, M. Jung, E.P. Kanter, H. Khemliche, S. Kravis, V. Mergel, M.H. Prior, H. Schmidt-Böcking, L. Spielberger, J. Ullrich, M. Unverzagt, and T. Vogt. *Phys. Rev. Lett.*, **77**:1024, 1996. see also erratum in *Phys. Rev. Lett.* **78**. 2031 (1997).
- [17] R. Dörner, H. Bräuning, J.M. Feagin, V. Mergel, O. Jagutzki, L. Spielberger, T. Vogt, H. Khemliche, M.H. Prior, J. Ullrich, C.L. Cocke, and H. Schmidt-Böcking. *Phys. Rev.*, **A57**:1074, 1998.
- [18] H.P Bräuning, R. Dörner, C.L. Cocke, M.H. Prior, B. Krässig, A. Kheifets, I. Bray, A. Bräuning-Demian, K. Carnes, S. Dreuil, V. Mergel, P. Richard, J. Ullrich, and H. Schmidt-Böcking. *J. Phys.*, **B31**:5149, 1998.
- [19] J. Briggs and V. Schmidt. *J. Phys.*, **33**:R1, 2000.
- [20] R. Dörner, V. Mergel, O. Jagutzki, L. Spielberger, J. Ullrich, R. Moshhammer, and H. Schmidt-Böcking. *Physics Reports*, **330**:96–192, 2000.
- [21] V. Mergel. PhD thesis, *Universität Frankfurt*. ISBN 3–8265–2067–X. Shaker Verlag, 1996.
- [22] K.J. Schafer, Baorui Yang, L.F. DiMauro, and K.C. Kulander. *Phys. Rev. Lett.*, **70**:1599, 1993.
- [23] O. Jagutzki, L. Spielberger, R. Dörner, S. Nüttgens, V. Mergel, H. Schmidt-Böcking, J. Ullrich, R.E. Olson, and U. Buck. *Zeitschrift für Physik*, **D36**:5, 1996.
- [24] J. Parker, K.T. Taylor, C.W. Clark, and S. Blodgett-Ford. *J. Phys.*, **B29**:L33, 1996.
- [25] R. Moshhammer, B. Feuerstein, W. Schmitt, A. Dorn, C.T. Schöter, J. Ullrich, H. Rottke, C. Trump, M. Wittmann, G. Korn, K. Hoffmann, and W. Sandner. *Phys. Rev. Lett.*, **84**:447, 2000.
- [26] A. Becker and F.H.M. Faisal. *Phys. Rev. Lett.*, **84**:3546, 2000.
- [27] K. Sacha and B. Eckhardt. *Phys. Rev.*, , submitted 2000.
- [28] K. Sacha and B. Eckhardt. *Los Alamos National Laboratory e-print*, :physics/0010031, 2000.